

## auto electrical parts

### Technical Information Sheet

#### Part No. 0-420-67

A powerful 9 x 3 watt 12/24 volt LED work lamp. Low current draw, 1.75 amp at 12 volt dc. Black powder coated die cast aluminium case, polycarbonate lens, supplied with stainless steel adjustable bracket and 450mm flying lead. Protected to IP67. I 116 x w 65 x h 137 mm.



#### Technical Drawing (not to scale)

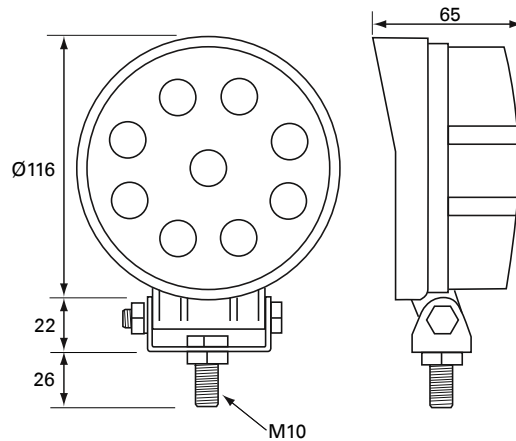

#### Specification

Type	LED work lamp
Voltage	10-30 volt dc
Current	1.75 amp at 12 volt dc
LEDs	9 x 3W Epistar LEDs
Light intensity	2150 lumens
Housing	Die cast aluminium
Bracket	Stainless steel
Lens	Polycarbonate
Degree of protection	IP67
Operating temperature	-40°C to +60°C
Weight	740g
Dimensions	I 116 x w 65 x h 137m

The information contained in this document is correct to the best of our knowledge at the time of printing. However, specifications may change at any time without notice.